

- () with independent rear axle steering
- () mit unabhängiger Hinterachslenkung

Duties with reduced outrigger base on request
Traglasten mit verkürzter Abstützbasis auf Anfrage

Dimensions in meters, weights and capacities in metric tonnes. For reference only.

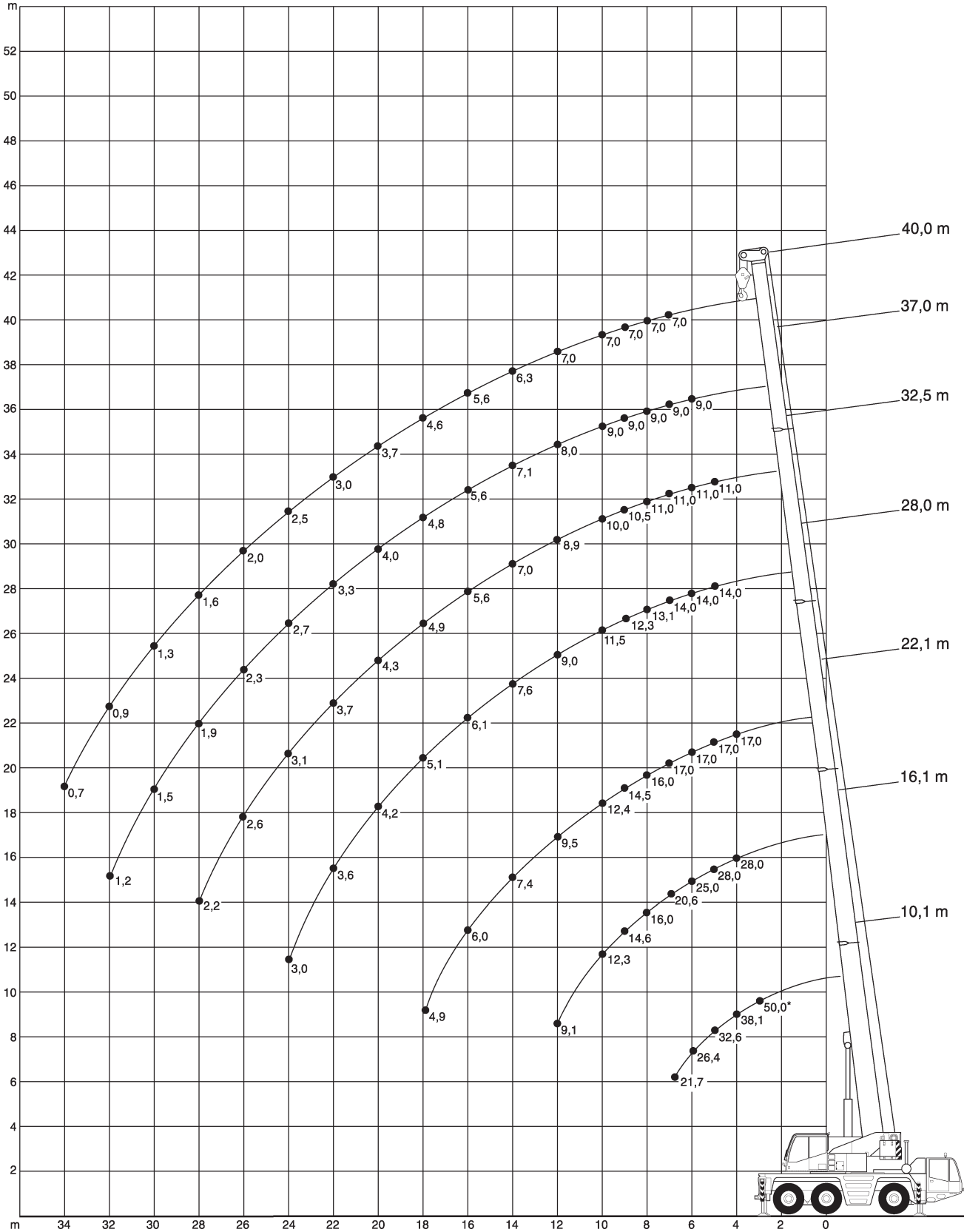



10,1-40m



9,5t



6,85x6,4m



360°



75%

m	10,1	16,1	22,1	28	32,5	37	40	m
3	50*							3
3	45,7							3
3,5	41,6	28						3,5
4	38,1	28	17					4
4,5	35,2	28	17	14				4,5
5	32,6	28	17	14	11			5
6	26,4	25	17	14	11	9		6
7	21,7	20,6	17	14	11	9	7	7
8		16	16	13,1	11	9	7	8
9		14,6	14,5	12,3	10,5	9	7	9
10		12,3	12,4	11,5	10	9	7	10
12		9,1	9,5	9	8,9	8	7	12
14			7,4	7,6	7	7,1	6,3	14
16			6	6,1	5,6	5,6	5,6	16
18			4,9	5,1	4,9	4,8	4,6	18
20				4,2	4,3	4	3,7	20
22				3,6	3,7	3,3	3	22
24				3	3,1	2,7	2,5	24
26					2,6	2,3	2	26
28					2,2	1,9	1,6	28
30						1,5	1,3	30
32						1,2	0,9	32
34							0,7	34

* over rear

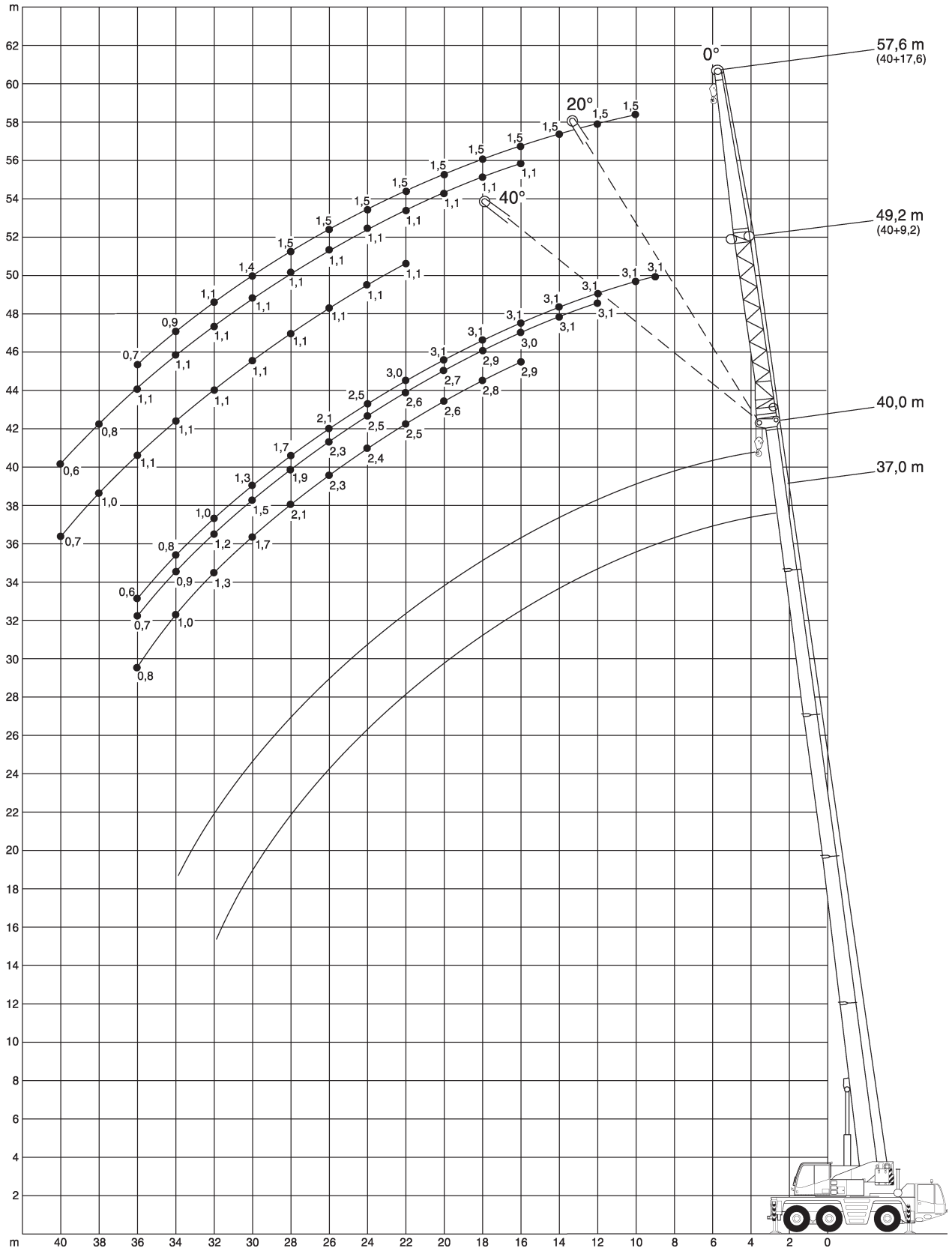



37-40m



9,2m



9,5t



6,85x6,4m



360°



75%

m	37			40			m
	0°	20°	40°	0°	20°	40°	
8	4,1						8
9	4,1			3,1			9
10	4,1			3,1			10
12	4,1	3,7		3,1	3,1		12
14	4	3,5	3,2	3,1	3,1		14
16	3,9	3,4	3,1	3,1	3	2,9	16
18	3,7	3,2	3	3,1	2,9	2,8	18
20	3,5	3,1	2,9	3,1	2,7	2,6	20
22	3,1	2,9	2,8	3	2,6	2,5	22
24	2,6	2,8	2,8	2,5	2,5	2,4	24
26	2,1	2,4	2,5	2,1	2,3	2,3	26
28	1,7	1,9	2,1	1,7	1,9	2,1	28
30	1,4	1,6	1,7	1,3	1,5	1,7	30
32	1,1	1,2	1,4	1	1,2	1,3	32
34	0,8	1	1,1	0,8	0,9	1	34
36	0,6	0,7		0,6	0,7	0,8	36



37-40m



17,6m



9,5t



6,85x6,4m



360°



75%

m	37			38,4	40			m
	0°	20°	40°	0°	0°	20°	40°	
10	1,8			1,5	1,1		10	
12	1,8			1,5	1,1		12	
14	1,8			1,5	1,1		14	
16	1,8	1,8		1,5	1,1	1,1	16	
18	1,8	1,7		1,5	1,1	1,1	18	
20	1,8	1,6		1,5	1,1	1,1	20	
22	1,7	1,6	1,5	1,5	1,1	1,1	1,1	22
24	1,7	1,5	1,5	1,5	1,1	1,1	1,1	24
26	1,6	1,5	1,4	1,5	1,1	1,1	1,1	26
28	1,5	1,4	1,4	1,5	1,1	1,1	1,1	28
30	1,5	1,4	1,3	1,4	1,1	1,1	1,1	30
32	1,2	1,3	1,3	1,1	1,1	1,1	1,1	32
34	1	1,3	1,2	0,9	0,9	1,1	1,1	34
36	0,8	1	1,2	0,7	0,7	1	1,1	36
38		0,8	1			0,8	1	38
40		0,6	0,8			0,6	0,7	40

